











PART		Qty.
A		5
B		1
C		1
D		1
E		1
F	 M8x16	3
G	 Ø9x19	3
H		1
I		2
J	 M6x30	6
K	 Ø7.5x15	6
L	 10mm	2

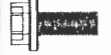

### Back height adjustment:

To change the back height (①), lift up the back by putting your force at the bottom of the back, then adjust the back height step by step. Only the back reach the highest position, then can pull down the back to the first position(lowest position).

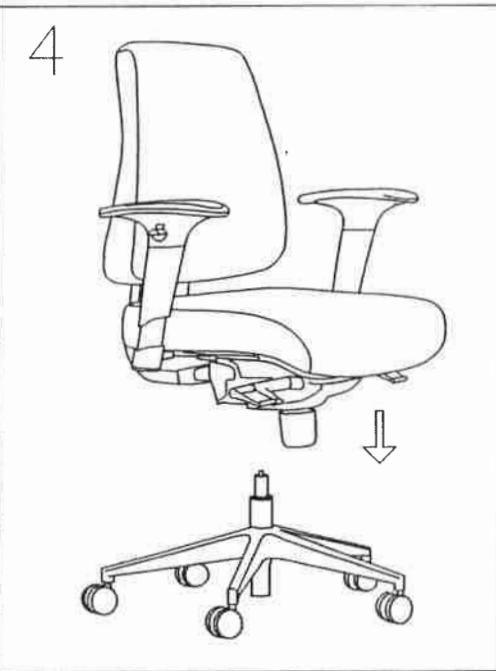
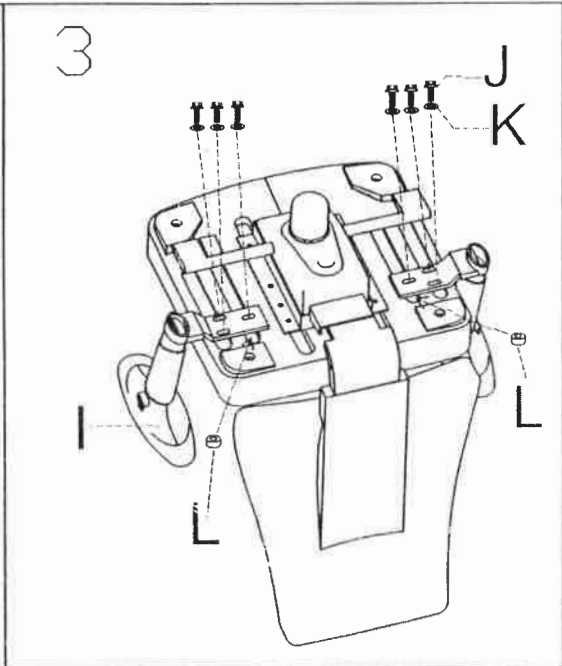
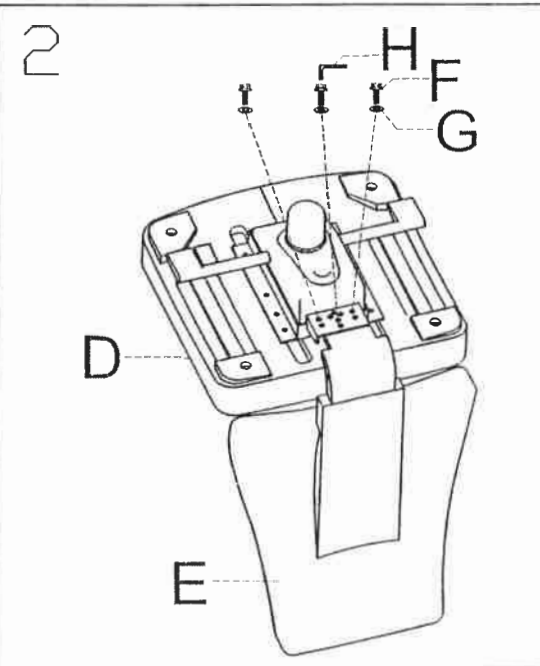
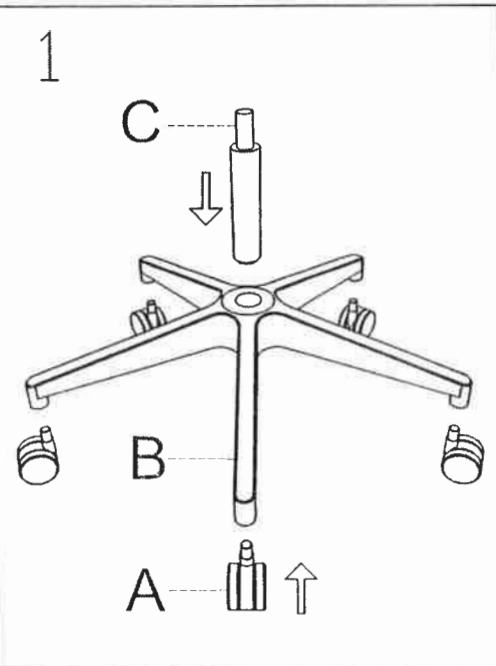
### Armrest adjustment (②):

To rise up or lower down the armrest, pull up the button on the armrest and move up or down.

### Seat height adjustment:

To raise the seat height, remove weight from the seat and pull up on the height adjustment lever (③), release the lever when reaching the desired position. To lower the seat height, while seated, pull up slowly on the height adjustment lever until the seat is at the desired height.



### Backrest angle adjustment (Tilt Lock):

To change backrest's position, pull up the adjustment lever (④), then lie backwards the backrest to desired position, and push down the adjustment lever to lock.

To go back to the first position, pull up the adjustment lever, lie backwards again and then backrest will return automatically.

### Seat depth adjustment:

To enlarge the seat depth, push down the slider lever (⑤) and move forward to desired position, then release the lever.

To go back to the first position, push down the slider lever and remove body weight from the seat.

### Tilt tension adjustment:

To adjust the seat tilt tension, turn the tension adjustment knob (⑥) on the mechanism to desired tension, turn clockwise or anticlockwise. Clockwise to stronger and anticlockwise to weaker.